

	ITEM	PART NO	DESCRIPTION	QTY.
	1	7106393	FRAME, BASE ASSY FLAT BLACK WITH LABELS	1
	2	7105460	HANDLE, REAR ASSEMBLY WITH LABELS	1
†	2.1		HANDLE, REAR BLACK DXPW 18GA. 13.25"	1
†	2.2		SCREW , TORX PANHEAD TT 1/4"-20 x 3/4"	4
	2.3	7109345	DASHBOARD SERVICE KIT WITH LABEL	1
	3	7105374	HANDLE, SVC ASSEMBLY QUICK START WITH LABELS	1
	4	7105461	ENGINE KIT, HONDA GX390 W/SHAFT KEY AND LABELS	1
	5	7105453	KEY, SHAFT 1/4" X 1/4" X 1-1/2"	1
	6	7109342	PUMP, SVC ASSY C45 AAA (530006)	1
	7	7105376	KIT, 13" WHEEL SERVICE	2
†	7.1		WHEEL, 13" BLACK	1
†	7.2		WASHER, 5/8" FLAT	1
†	7.3		CLIP, E-TYPE 0.625" x 0.042"	1
	8	7103292	KIT, FOOT SVC ASY .625"	2
†	8.1		FOOT, RUBBER 1.5"ODx.625"-5/16 INSERT	1
†	8.2		SCREW , TORX PANHEAD TT 1/4"-20 x 3/4"	1
	9	7103277	HARDWARE KIT, ENGINE MOUNTING	1
	9.1		BOLT, 3/8"-16 x 2" SERRATED FLANGE	4
†	9.2		NUT, 3/8"-16 WHIZ	4
	10	7103279	KIT, PUMP MOUNTING HARDWARE	1
†	10.1		BOLT, 3/8"-16 x 1 1/4"	4
†	10.2		WASHER, 3/8" SPLIT-LOCK	4
	11	7107941	KNOB-BOLT ASSEMBLY	2
†	11.1		BOLT, SADDLE 5/16"-18 x 2"	1
†	11.2		KNOB, HANDLE 5/16-18	1
	12	7101683	NOZZLE SET, 4.0 5PC 1/4" QC-M	1
	13	7104641	HANDLE GRIP, VINYL COVER DEWALT	1
	14	7108127	GUN, 4500PSI, 6.6GPM, 3/8 QC(M) W/SIDE H	1
	15	7103261	LANCE, 31" 1/4"QC-F x M22(M)	1
	16	7104844	HOSE, 3/8" X 50' X 4500PSI 3/8QC	1
	17	7102207	KIT, SVC ASSY SOAP HOSE W/PLASTIC FILTER	1
*	18	7102045	TOOL, NOZZLE CLEANING, UNIVERSAL	1
*	19	7104834	MANUAL, DXPW4240 MODEL SPECIFIC OPERATOR'S	1
*	20	7104833	BOX, DXPW4240 MODEL SPECIFIC SHIPPING	1

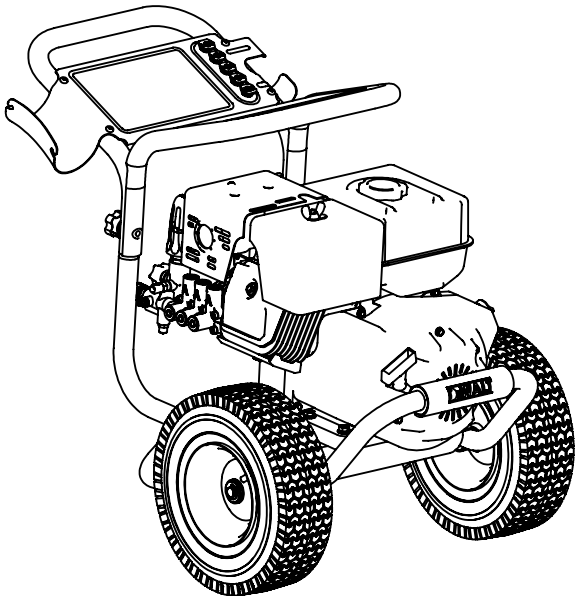

\* NOT SHOWN  
† NOT SOLD SEPERATELY

PUMP INFORMATION TABLE			
MACHINE SERIAL NO.	PUMP TYPE	PUMP PART NO.	PUMP KIT NO.
128497 TO 984158	4200PSI @ 4.2GPM	7104820	7105462
984159 TO 1324798	AAA C45 SERIES	530006	7109342
1324799 TO PRESENT	4200PSI @ 4.2GPM	7104820	7105462

	NAME	DATE
DRAWN	RV	9/26/2016
CHECKED	M.G.	5/6/2014
ENG APPR.	S.A.C.	5/6/2014
MFG APPR.	S.A.C.	2/8/2012
Q.A. APPR.	J.C.	5/6/2014
SERVICE APPR.	D.H.	2/7/2012

**PROPRIETARY AND CONFIDENTIAL**  
THE INFORMATION CONTAINED IN THIS DRAWING IS THE SOLE PROPERTY OF FNA-GROUP. ANY REPRODUCTION IN PART OR AS A WHOLE WITHOUT THE WRITTEN PERMISSION OF FNA-GROUP IS PROHIBITED.

FNA-GROUP		
1265 INDUSTRIAL STREET, DECATUR, AR 72722		
TITLE:		
<b>DXPW4240 DEWALT4200PSI</b>		
SIZE	DWG. NO.	REV.
<b>A</b>	<b>60577-S</b>	<b>D</b>
SCALE: N/A	ECN# DC16-0309	SHEET 1 OF 4

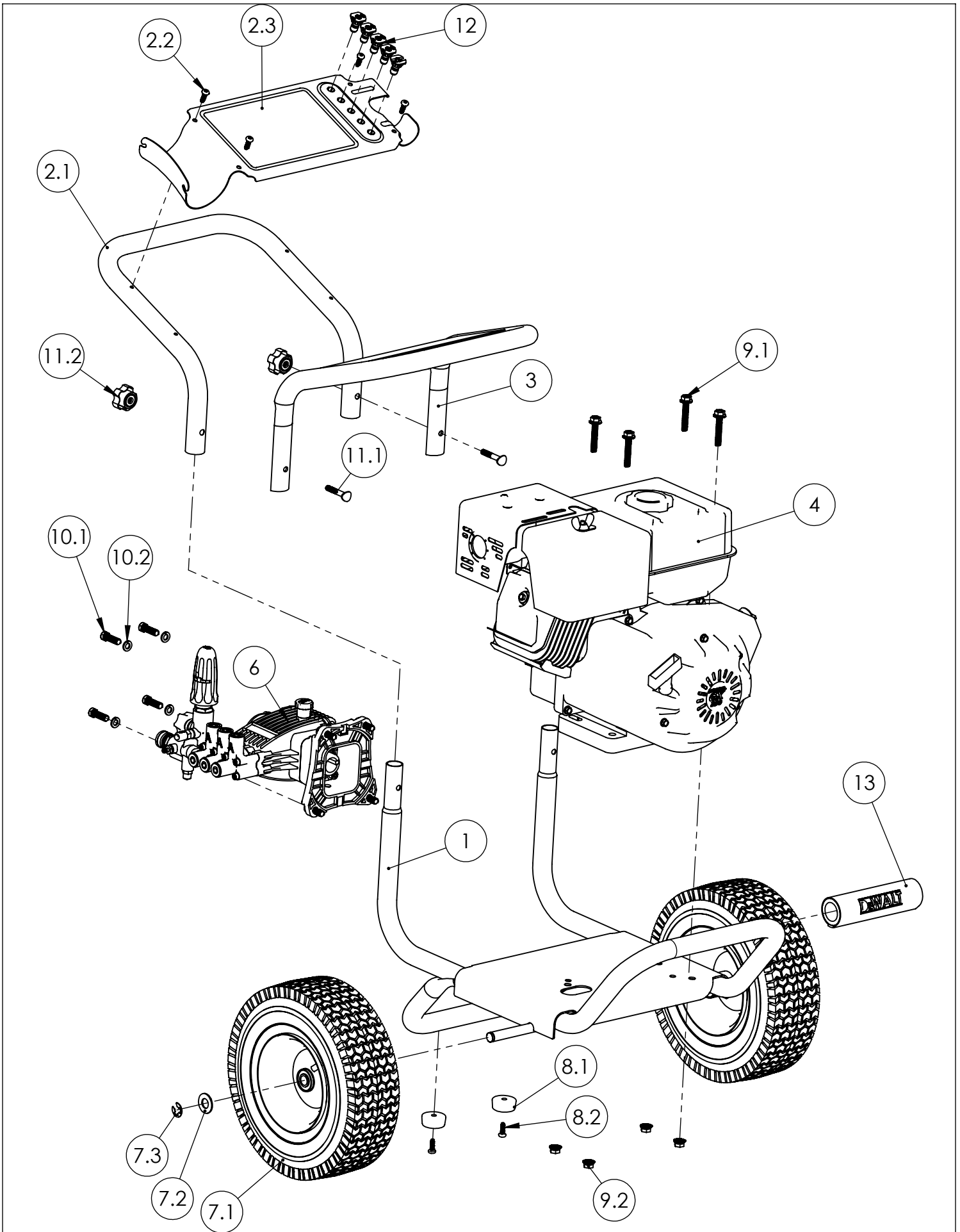

SIZE	DWG. NO.	REV.
<b>A</b>	<b>60577-S</b>	<b>D</b>
SCALE: N/A	ECN# DC16-0309	SHEET 2 OF 4

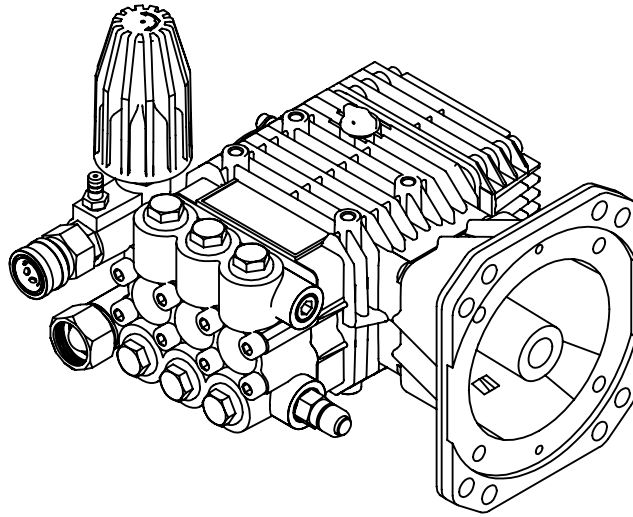

PUMP, ZWD-K4042 SERVICE KIT  
PART NO. 7105462

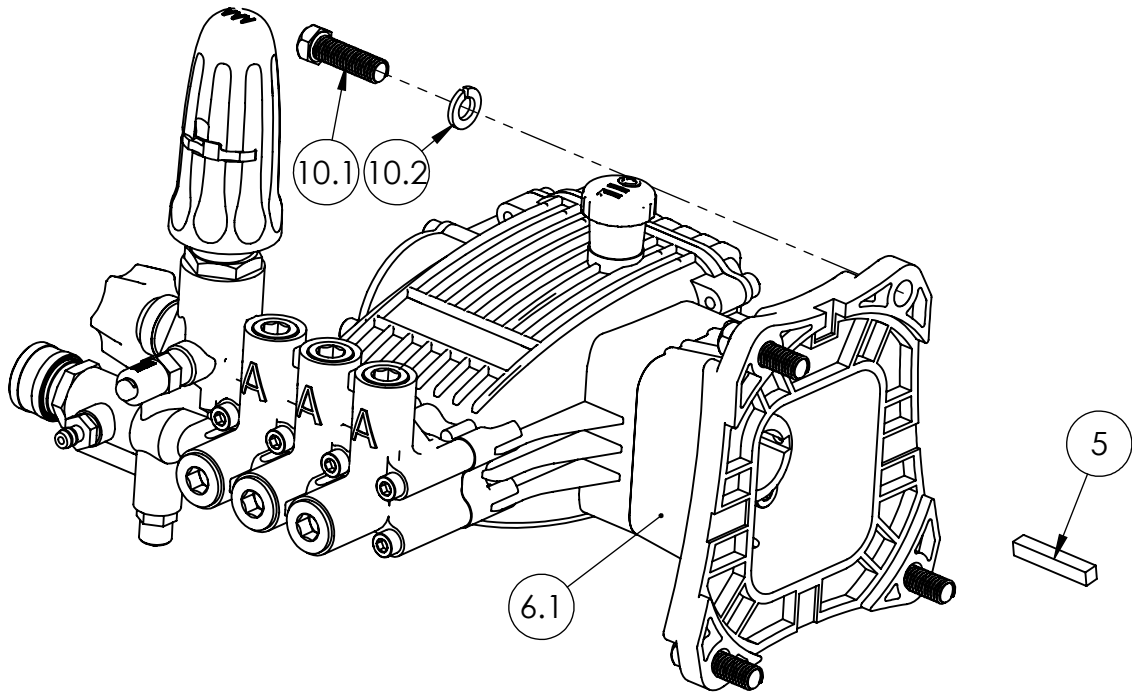

DXPW4240 DEWALT4200PSI  
PART NO. 7109342

ITEM	PART NO	DESCRIPTION	QTY.
5	7105453	KEY, SHAFT 1/4" X 1/4" X 1-1/2"	1
6.1	530006	PUMP, 4200PSI @ 4.0 GPM HORIZONTAL TRIPLEX DIRECT DRIVE (C45)	1
10	7103279	KIT, PUMP MOUNTING HARDWARE	1
10.1		BOLT, 3/8"-16 x 1 1/4"	4
10.2		WASHER, 3/8" SPLIT-LOCK	4
17	7102207	KIT, SVC ASSY SOAP HOSE W/PLASTIC FILTER	1

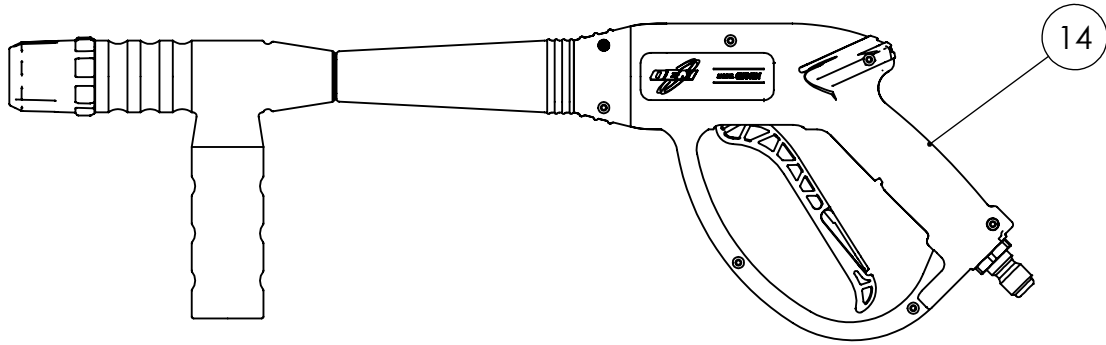

GUN, 4500PSI, 6.6GPM, 3/8 QC(M) W/SIDE H  
PART NO. 7108127



LANCE, 31" M22(M) x 1/4" QC-F  
PART NO. 7103261

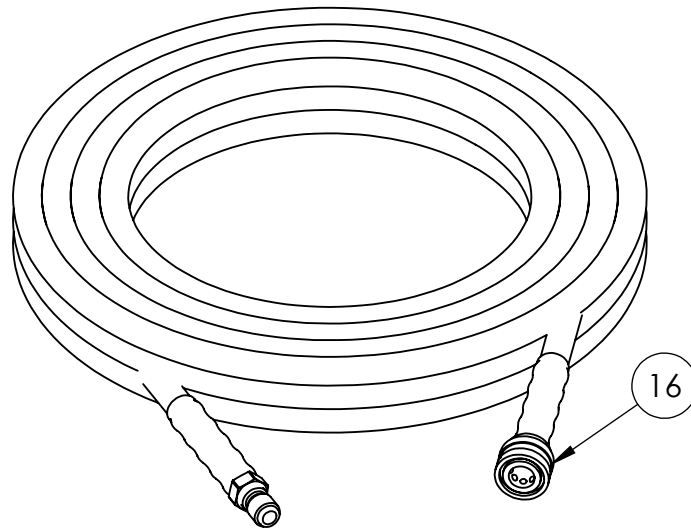

HOSE, 3/8" x 50' x 4500PSI 3/8" QC-M x 3/8" QC-F RUBBER  
PART NO. 7104844

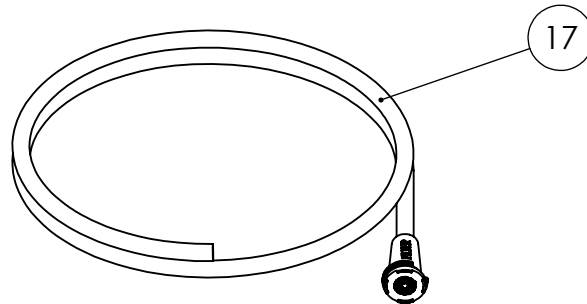

KIT, SVC ASSY SOAP HOSE W/PLASTIC FILTER  
PART NO. 7102207

SIZE	DWG. NO.	REV.
<b>A</b>	60577-S	<b>D</b>
SCALE: N/A	ECN# DC16-0309	SHEET 4 OF 4

TORQUE SPECIFICATIONS			
ITEM	FT-LB	IN-LB	N-M
2	9	106	12
3	15	177	20
6	13	159	18
7	3	35	4
13	15	177	20
16	15	177	20
22	15	177	20
24	7	80	9
26	15	177	20
27	7	80	9
35	7	80	9
36	19	222	25
50	13	159	18

REV.	DESCRIPTION	REVISIONS		
		ECN#	APPROVED	DATE
A	NEW RELEASE	DC16-0189	D.H.	6/8/16

# 530006 PUMP SERVICE DRAWING

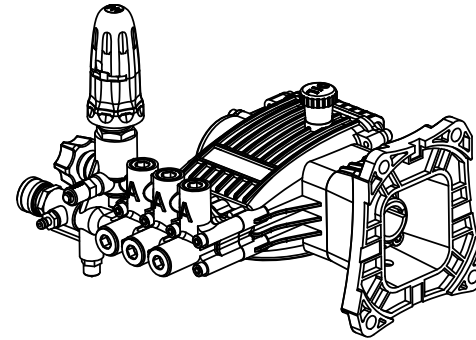

NOTE: ITEM 43 TO BE INSTALLED BY CUSTOMER  
 1) REMOVE TOP PLUG & O-RING ONLY (ITEMS 44 & 45)  
 2) REPLACE WITH VENT PLUG (ITEM 43)

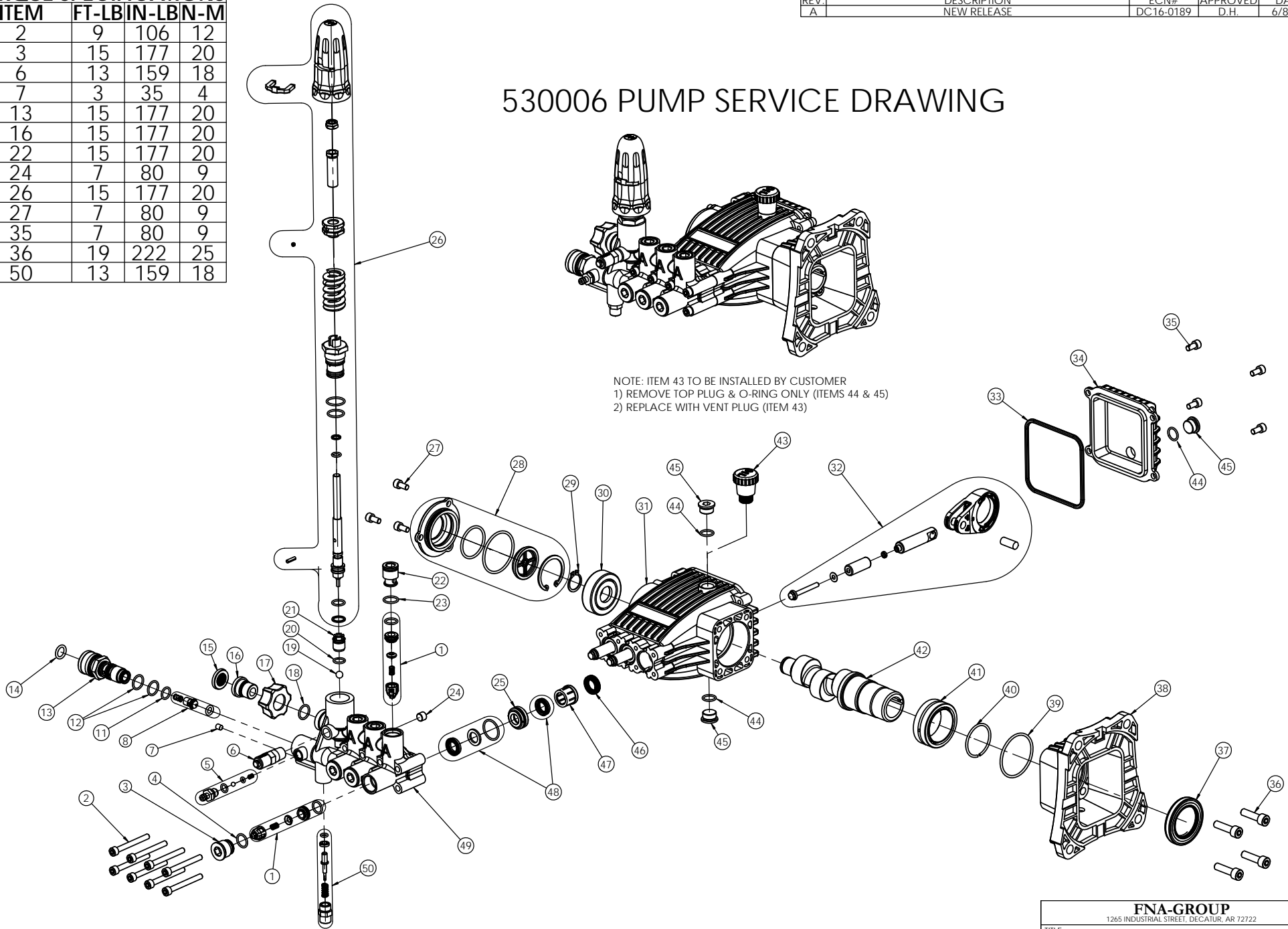

<b>FNA-GROUP</b> 1265 INDUSTRIAL STREET, DECATUR, AR 72722		
TITLE: PUMP, 4200PSI @ 4.0 GPM HORIZONTAL TRIPLEX DIRECT DRIVE (C45)		
SIZE: <b>C</b>	DWG. NO.: <b>530006</b>	REV: <b>A</b>
WEIGHT: 15.410 lbs	SCALE: 1:3	SHEET 1 OF 6

# 530006 PARTS LIST

ITEM	PART NO.	DESCRIPTION	QTY
1	7108750	CAGE, VALVE	6
		SPRING, VALVE	
		DISK, VALVE	
		O-RING	
		SEAT, VALVE	
2	7106692	SCREW	8
3	7106693	PLUG	3
4	7106694	O-RING	3
5	7104228	HOSE BARB	1
		O-RING	
		O-RING	
		BALL, SOAP VALVE	
6	7101359	SPRING, SOAP VALVE	1
		VALVE, THERMAL RELIEF	
7	7109053	PLUG	1
8	7109054	O-RING, CHECK VALVE	1
		CORE, NON-RETURN CHECK VALVE	
		SPRING, CHECK VALVE	
11	7106699	O-RING	1
12	7106700	O-RING	2
13	7106701	QUICK CONNECT CONNECTOR, OUTLET	1
14	7106702	O-RING	1
15	7000123	SCREEN, WATER INLET	1
16	7106703	INLET, CONNECTOR	1
17	7105705	NUT, HAND TIGHT	1
18	7106704	O-RING	1
19	7109055	BALL	1
20	7109056	O-RING	2
21	7109057	UNLOADER VALVE SEAT	1
22	7106707	PLUG	3
23	7106700	O-RING	3
24	7106647	PLUG	1
25	7106710	RETAINER	3
26	7109058	UNLOADER CAP	1
		CAP LOCKER	
		NUT M6	
		SCREW	
		UNLOADER NUT	
		SET SCREW	
		UNLOADER SPRING	
		UNLOADER VALVE CAP	
		O-RING, 15X1.8	
		O-RING, 14X1.8	
		BACK UP RING	
		O-RING, 5.6X1.8	
		LOCK PIN	
		STEM ASSY	
O-RING, 9X1.8			
BACK UP RING			

ITEM	PART NO.	DESCRIPTION	QTY
27	7106721	SCREW	3
28	7106709	COVER, SIDE	1
		O-RING	
		O-RING	
		SIGHT GLASS	
29	7106714	RING Ø20, RETAINING	1
30	7109059	BEARING, NUP 304E	1
31	7109060	CRANKCASE	1
32	7109061	BOLT	3
		GASKET	
		PLUNGER, CERAMIC	
		RING	
		PLUNGER, POLE, BASE	
33	7106719	CONNECTING ROD	1
		PIN, CONNECTING ROD	
		O-RING	
34	7109062	CRANKCASE, END COVER	1
35	7106721	SCREW	4
36	7106722	SCREW	4
37	7106723	OIL SEAL	1
38	7106724	FLANGE	1
39	7106712	O-RING	1
40	7106726	RING Ø40, RETAINING	1
41	7106727	NEEDLE BEARING	1
42	7109063	CRANKSHAFT, Ø11.6mm	1
43	7108868	VENT CAP	1
44	7106730	O-RING	3
45	7105721	PLUG	3
46	7106731	OIL SEAL	3
47	7109064	RETAINER, SEAL	3
48	7106733	SEAL, LOW PRESSURE	1
		O-RING	
		RING, ANTI-EXT	
49	7109065	SEAL, HIGH PRESSURE	1
		MANIFOLD	
50	7106628	VALVE CAP, PRESSURE BOOST	1
		SPRING, BOOST VALVE	
		VALVE, PRESSURE BOOST	
		BACK RING	
51	7108989	O-RING	1
52	7108991	OIL SEAL KIT	1
53	7109066	PLUNGER KIT	1
54	7109067	UNLOADER KNOB KIT	1
55	7109068	MANIFOLD KIT	1
		CRANKCASE KIT	1

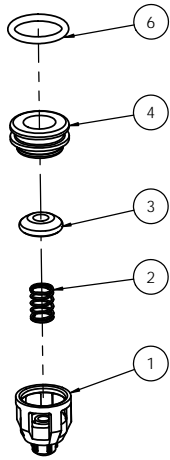

① **PART NO. 7108750**  
VALVE KIT

ITEM	QTY	DESCRIPTION
1	6	CAGE, VALVE
2	6	SPRING, VALVE
3	6	DISK, VALVE
4	6	SEAT, VALVE
5	6	O-RING

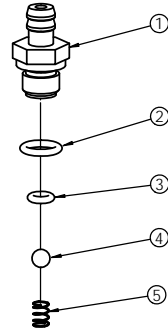

⑤ **PART NO. 7104228**  
SOAP INJECTOR KIT

ITEM	QTY	DESCRIPTION
1	1	HOSE BARB
2	1	O-RING
3	1	O-RING
4	1	BALL, SOAP VALVE
5	1	SPRING, SOAP VALVE

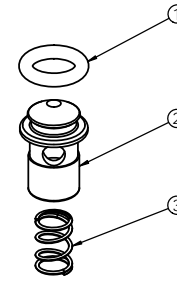

⑧ **PART NO. 7109054**  
UNLOADER CHECK VALVE KIT

ITEM	QTY	DESCRIPTION
1	1	O-RING, CHECK VALVE
2	1	CORE, CHECK VALVE
3	1	SPRING, CHECK VALVE

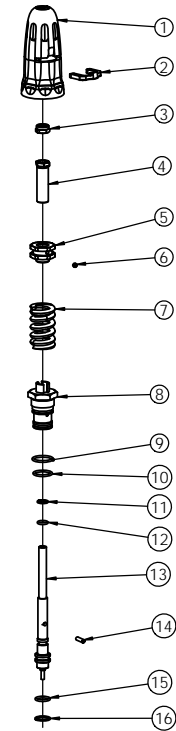

②⑥ **PART NO. 7109058**  
UNLOADER KIT

ITEM	QTY	DESCRIPTION
1	1	UNLOADER CAP
2	1	CAP LOCKER
3	1	NUT M8
4	1	SCREW
5	1	UNLOADER NUT
6	1	SET SCREW
7	1	UNLOADER SPRING
8	1	UNLOADER VALVE CAP
9	1	O-RING, 19X1.8
10	1	O-RING, 17X1.8
11	1	BACK UP RING
12	1	O-RING, 8X1.8
13	1	STEM ASSY
14	1	LOCK PIN
15	1	O-RING, 12.5X1.8
16	1	BACK UP RING

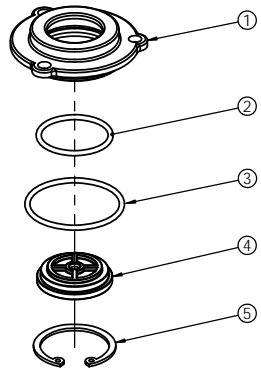

②⑧ **PART NO. 7106709**  
CRANKCASE SIGHTGLASS KIT

ITEM	QTY	DESCRIPTION
1	1	COVER, SIDE
2	1	O-RING
3	1	O-RING
4	1	SIGHT GLASS
5	1	RING Ø40, RETAINING

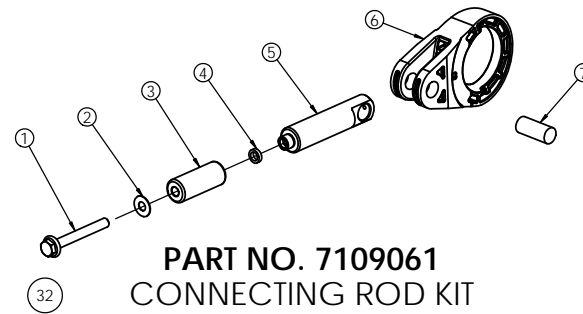

③② **PART NO. 7109061**  
CONNECTING ROD KIT

ITEM	QTY	DESCRIPTION
1	3	BOLT
2	3	GASKET
3	3	PLUNGER, CERAMIC
4	3	RING
5	3	PLUNGER, POLE, BASE
6	3	CONNECTING ROD
7	3	PIN, CONNECTING ROD

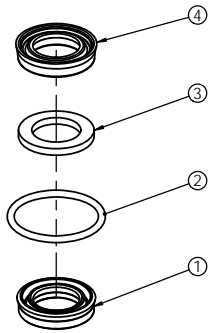

48 PART NO. 7106733  
HIGH AND LOW PRESSURE SEAL KIT

ITEM	QTY	DESCRIPTION
1	3	SEAL, LOW PRESSURE
2	3	O-RING
3	3	RING, ANTI-EXT
4	3	SEAL, HIGH PRESSURE

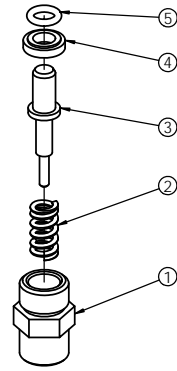

50 PART NO. 7106628  
PRESSURE BOOST VALVE KIT

ITEM	QTY	DESCRIPTION
1	1	VALVE CAP, PRESSURE BOOST
2	1	SPRING, BOOST VALVE
3	1	VALVE, PRESSURE BOOST
4	1	BACK RING
5	1	O-RING

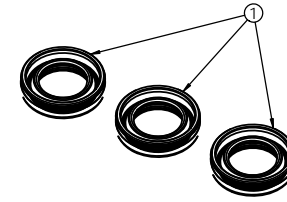

51 PART NO. 7108989  
OIL SEAL KIT

ITEM	QTY	DESCRIPTION
1	3	OIL SEAL

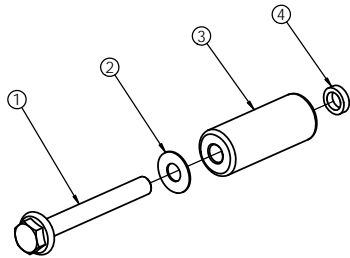

52 PART NO. 7108991  
PLUNGER KIT

ITEM	QTY	DESCRIPTION
1	3	BOLT
2	3	GASKET
3	3	PLUNGER, CERAMIC
4	3	RING

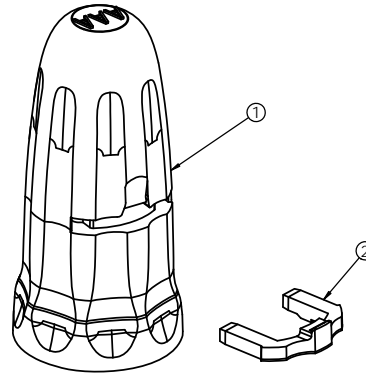

53 PART NO. 7109066  
UNLOADER KNOB KIT

ITEM	QTY	DESCRIPTION
1	1	UNLOADER CAP
2	1	CAP LOCKER



54 PART NO. 7109067  
MANIFOLD KIT

ITEM	QTY	DESCRIPTION
1	6	CAGE, VALVE
		SPRING, VALVE
		DISK, VALVE
		O-RING
		SEAT, VALVE
2	8	SCREW
3	3	PLUG
4	3	O-RING
5	1	HOSE BARB
		O-RING
		O-RING
		BALL, SOAP VALVE
6	1	SPRING, SOAP VALVE
		VALVE, THERMAL RELIEF
7	1	PLUG
8	1	O-RING, CHECK VALVE
		CORE, NON-RETURN CHECK VALVE
		SPRING, CHECK VALVE
11	1	O-RING
12	2	O-RING
13	1	QUICK CONNECT CONNECTOR, OUTLET
14	1	O-RING
15	1	SCREEN, WATER INLET
16	1	INLET, CONNECTOR
17	1	NUT, HAND TIGHT
18	1	O-RING
19	1	BALL
20	2	O-RING
21	1	UNLOADER VALVE SEAT
22	3	PLUG
23	3	O-RING
24	1	PLUG
25	3	RETAINER
26	1	UNLOADER CAP
		CAP LOCKER
		NUT M6
		SCREW
		UNLOADER NUT
		SET SCREW
		UNLOADER SPRING
		UNLOADER VALVE CAP
		O-RING, 15X1.8
		O-RING, 14X1.8
		BACK UP RING
		O-RING, 5.6X1.8
		LOCK PIN
		STEM ASSY
		O-RING, 9X1.8
		BACK UP RING
		SEAL, LOW PRESSURE
		48
48	1	RING, ANTI-EXT
		SEAL, HIGH PRESSURE
49	1	MANIFOLD
50	1	VALVE CAP, PRESSURE BOOST
		SPRING, BOOST VALVE
		VALVE, PRESSURE BOOST
		BACK RING
		O-RING

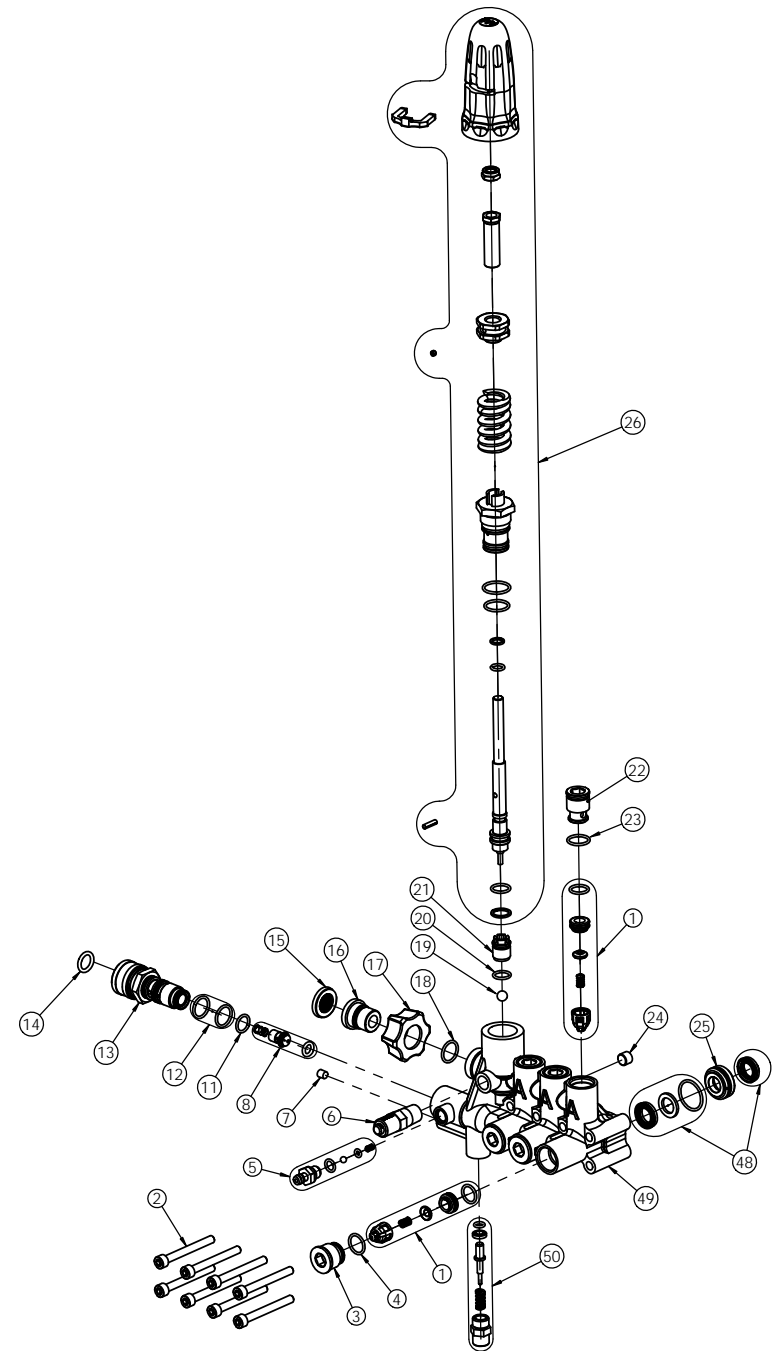

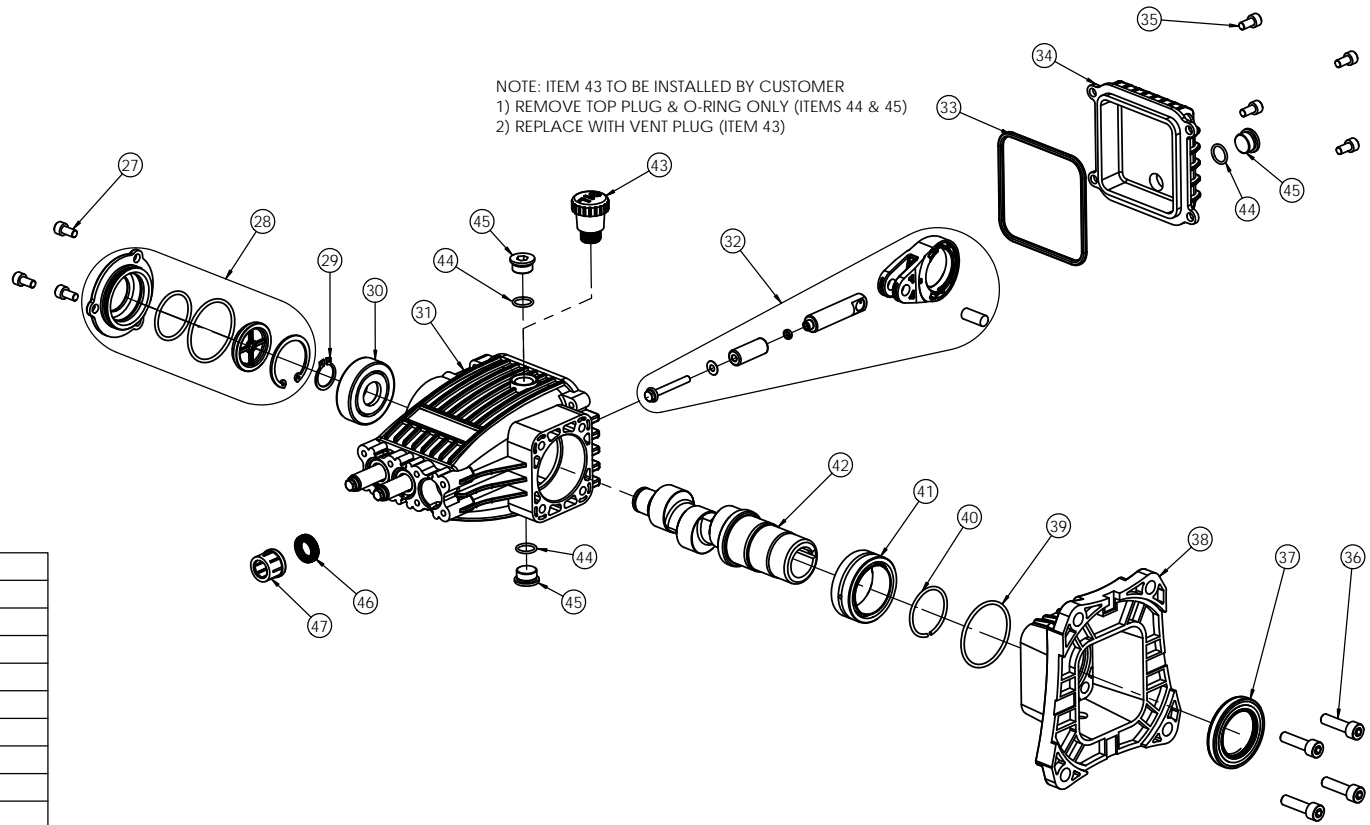

55 **PART NO. 7109068**  
CRANKCASE KIT

ITEM	QTY	DESCRIPTION
27	3	SCREW
28	1	COVER, SIDE
		O-RING
		SIGHT GLASS
29	1	RING Ø20, RETAINING
30	1	BEARING, NUP 304E
31	1	CRANKCASE
32	3	BOLT
		GASKET
		PLUNGER, CERAMIC
		RING
		PLUNGER, POLE, BASE
		CONNECTING ROD
		PIN, CONNECTING ROD
33	1	O-RING
34	1	CRANKCASE, END COVER
35	4	SCREW
36	4	SCREW
37	1	OIL SEAL
38	1	FLANGE
39	1	O-RING
40	1	RING Ø40, RETAINING
41	1	NEEDLE BEARING
42	1	CRANKSHAFT, Ø11.6mm
43	1	VENT CAP
44	3	O-RING
45	3	PLUG
46	3	OIL SEAL
47	3	RETAINER, SEAL